

A white paper from **Active Thermal Management**
The trusted name in thermal protection

By Frank Federman, CEO

Cooling the enclosed video projector

A question we are frequently asked is "how can we cool a video projector that's in an enclosure?" The question we ask right back is "Why did you enclose the projector?" Video projectors are frequently enclosed, but not for the reasons of a few years ago. CRT projectors, the only game in town for many years, were inherently quiet; few had fans, and those that did weren't especially loud. CRT projectors were enclosed simply to disguise them. When fixed-matrix projectors began replacing the CRT in home theaters, many were products which had been designed for commercial use. Brighter and smaller than CRT-based projectors, they were also considerably louder. High-wattage projection bulbs needed cooling, but training sessions and sales presentations didn't require low noise levels; these projectors were LOUD..... Those projectors were enclosed (and tightly!) to muffle the loud fan noises they generated when they were used in residential installations.

The scene has changed. Many of the projectors on the market today have been specifically designed for home use. Part of the redesign for this market has been to significantly reduce noise, both from the fan motors and the movement of air through cooling passages. Nevertheless, some projectors still produce more noise than is acceptable in quiet theaters in which projectors are located close to the audience. There is also a desire in many cases to hide the projector for aesthetic reasons.

So the client needs only a bit of noise reduction and perhaps a bit of camouflage. This makes life much easier, as a partial enclosure can usually achieve both objectives.

What follows should be taken as general information and guidance. There are many projectors on the market, and frequent model changes. It would be impractical to try to describe, in detail, enclosure techniques covering all projectors being enclosed for all possible reasons to fit in all possible room arrangements! Nevertheless, there are elements common

to all enclosure projects; we trust the information presented here will be helpful.

A five-sided box (front completely open) is almost always enough to absorb the annoying frequency components present in fan noise, reducing overall noise to a level acceptable to most clients. 5/8" MDF (medium density fiberboard) is readily available, inexpensive, and ready to paint. Simple glue-and-screw construction quickly produces an effective noise reducing enclosure, especially if you hire a cabinet maker to build it for you! Lining the enclosure with material that absorbs noise travelling along its surface, rather than blocking the transmission of sound through its thickness, will buy another few dB of noise reduction, but be certain to specify a material with appropriate flammability characteristics.

By the way....while we're letting the lawyers supervise our installations, don't forget to allow for the weight of the enclosure, frequently greater than the weight of the projector, when planning the mounting method. Remember that your client, his family, and guests will be sitting under that projector for years to come.....! A recent survey indicates that most clients would rather not have their video projector fall on their mother-in-law's head, unless it was time for a new one! (The survey did not, however, indicate whether that meant that it was time for a new projector or a new mother-in-law...)

We've enclosed the projector; even with a partial enclosure, however, projectors are likely to overheat, as we've restricted both the ability of the projector to inhale fresh air and its ability to exhale heated air. While there's a WIDE range of locations on today's projectors for intake and exhaust ports, almost all projectors will run hotter in a five-, or even four-sided enclosure than they will when not enclosed..

Fortunately, it's relatively easy to help projectors inhale and exhale. Active Thermal Management makes a full range of very quiet cooling systems, several of which are particularly appropriate for the situations described above. There are two relatively easy ways to cool an enclosed projector:

1. Move the heated air out into the immediate vicinity of the projector enclosure. (We'll call this "The first way".)
2. Move the heated air into another area. (We'll call this - that's right - "The second way".)

In both cases, fresh air to replace the heated air being removed from the enclosure is taken from the area around the enclosure. While fresh air can be brought in from a remote location, this is rarely necessary.

The first way ---In most cases, simply boosting the flow of the projector's intake and exhaust fans is sufficient. An Active Thermal Management System 2 kit can be installed so that one of its fans forces air into the box near the projector's intake port while the other pulls the heated air from near the projector's exhaust port and moves it out of the box. Single chip DLP and LCD projectors dissipate only a few hundred watts, approximately 1000 BTUs; this amount of heat is easily lost in all but the smallest theaters. For reasonably quiet projectors, the System 2 fans can be placed in the box walls so that they line up with the projector's intake and exhaust ports (see Figure 1 for typical fan locations). For noisier projectors, the fans can be offset a few inches

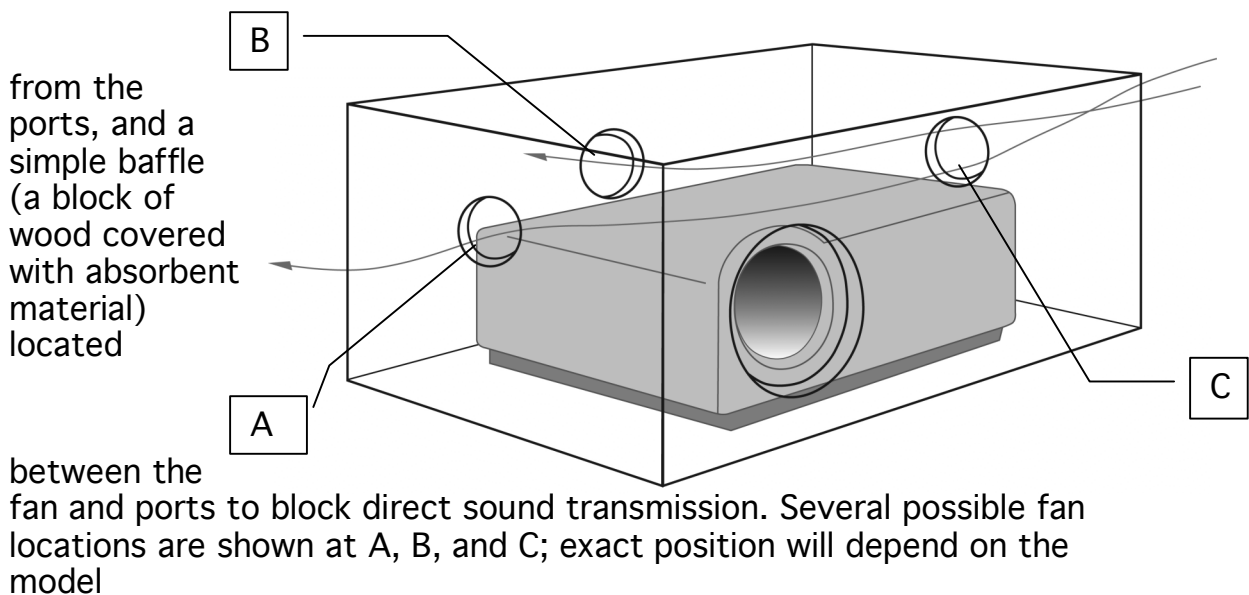

Figure 1

projector chosen. (If the exhaust port is on the front panel of the projector, and the front of the box is completely open, both fans can be

used in intake mode, placed side-by-side near the projector's intake grille. If the intake port is on the front panel, use both fans in exhaust mode near the exhaust port.)

For somewhat larger projectors, a System 2+2 Kit, with four fans, might be called for. Two can be used to bring fresh air in, while the other two exhaust the heated air out of the enclosure.

The goal is to locate the fans so that heated exhaust air is "grabbed" and moved out of the enclosure as soon as it exits the projector, so that it cannot circle back and be drawn into the projector's fresh air intake. The ventilation system chosen must be able to move as much air as the projector's own fan system, so that internal temperatures rise only as much as they would when the projector operates in an open environment.

The ATM System 2 Kit --- Whether two or four fans are used, the System 2 fans themselves generate extremely low noise levels. Their speed is controlled by an amplifier that feeds a variable duty cycle rectangle wave to them. At low temperatures, the duty cycle is 0; no power goes to the fans. At high temperatures (which won't be reached, since we're cooling the projector properly!), the duty cycle is 100%, and full (but much less than the fans would receive in ordinary applications) power is sent to the fans. A small temperature sensor is fastened to the projector at the exhaust port during installation, directly in the hot air stream. This assures that the fans will start shortly after projector turn-on, and will continue operating, slowing down as the projector's exhaust stream cools down after turn-off.

The second way -- The approach described above, moving room air in and out of the projector's enclosure, is a low-cost, easily installed cooling technique and works well in the majority of installation situations we've encountered. There are situations, however, in which it is necessary (or the client thinks it's necessary) to move the heated air out of the theater. A recently introduced Active Thermal Management product, the Cool-cube™, (Figure 2) is frequently the solution for this problem.

Consisting of a fan module, dual thermal switches, and a length of either 2", 3", or 4" (inside diameter) flexible tubing, the Cool-cube can move from 12 to more than 50 CFM of hot exhaust from the projector into a utility room, plenum, or attic.



Figure 2

The tubing comes with a hot air collector, an adapter which can be fastened to the projector so that no heated air can escape and be sucked into the projector's intake opening, the most frequent cause of projector overheating. (See figures 3 and 4.) A convenient way to fasten the hot air collector to the projector is to use bungee cords to hold the collector against the exhaust port. Padded (to prevent scratching the projector's finish) and easily removed for relamping, the elasticity of the cords helps keep the collector in close contact with the projector's exhaust port.

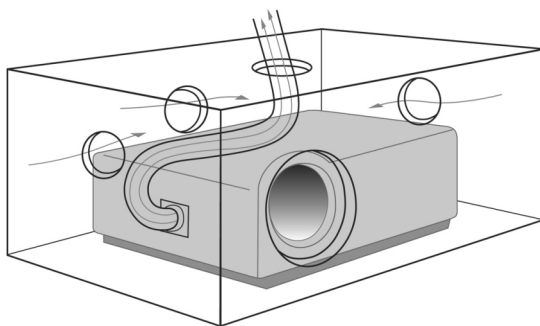

Figure 3

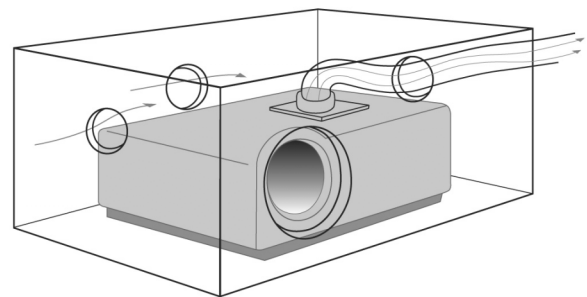

Figure 4

The most common arrangement when using the Cool-cube to remove a projector's exhaust heat is to bring the tubing up to an attic or out to an adjoining area, such as a utility room. If the heated air is being vented into an attic, or any other area in which the air may reach high or low temperatures, or in which there may be dust, odors, insects, etc., a

backdraft damper is necessary. Cool-cube can be used with an ordinary clothes dryer vent hood to prevent these nuisances from entering the projector enclosure when the fans are not turning.

For larger heat loads, such as three-chip DLP projectors, or cases in which the projector's exhaust must be moved a long distance, the Active Thermal Management System 1 can be used. The System 1 consists of an in-line centrifugal blower



Figure 5

capable of moving large amounts of air up to 25 feet, acoustically-insulated tubing, and a hot air collector (see Figure 5). It is also available (as the System 1 EXT) in a weatherproof enclosure which can be mounted outside the home. Whether using the Cool-cube or the more powerful System 1, fresh air must still be supplied to the projector. Passive venting is sufficient; an opening, possibly baffled by a block of wood covered with sound absorbent material near the projector's intake will allow fresh air to enter the enclosure, pulled in by both the projector's fans and the auxiliary venting method.

Again, the most important point to remember when enclosing a video projector (beside not letting it fall on peoples' heads) is to arrange airflow so that no hot exhaust air can recirculate through the projector's intake port.

There is a relatively simple test you can perform that will indicate whether you have provided sufficient ventilation for the projector you've enclosed; you don't have to guess, or wait for a call from an upset client...!

1. Using a digital thermometer with an external probe, (readily available at Radio Shack and other electronics suppliers), measure the temperature of the projector's exhaust air when it's sitting out in the open. (Tape or otherwise fasten the probe to the projector case so that it can't move.) Let the projector run long enough to insure that it's as hot as it's going to get, i.e., the thermometer reading is steady. Note the temperature and turn the projector off.

2. Carefully place the projector in the enclosure, not allowing the probe to shift position. It should be possible to feed the probe wire out of the enclosure so that you can measure the projector's exhaust temperature while it's mounted in what will be its normal operating position. Turn on the ventilating equipment.

3. Let the projector run until the temperature of the exhaust stream again reaches its highest temperature.

If the exhaust temperature hasn't increased by more than a few degrees over the original reading, the projector is being properly ventilated. It's possible that the temperature may even decrease slightly, indicating that the extra ventilation is causing somewhat higher airflow through the projector than normal.

Finally, a few (very few) words about 2 related situations which you should not run into often:

- The completely enclosed projector
- The completely enclosed projector which requires that fresh air be supplied from a remote location

It is occasionally necessary to enclose very loud projectors (there are still some around) in six-sided boxes. In these situations, we have found that it is generally not necessary to use glass over the lens opening; truly high-quality optical glass is expensive and difficult to handle without damage. Making an opening about an inch larger in diameter than the lens allows for some adjustment during installation and for at least some of the air needed for ventilation.

If a truly sealed enclosure is used, it is possible to use the technique described above in "The second way" to bring fresh air in from a remote area, should this be required. Two venting systems would be used, one bringing fresh air in while a second moves heated air out.

This last approach should be considered only if absolutely necessary, as it represents an expensive and complicated approach to projector enclosure, and is far beyond what is required in the majority of installations.

Contact Active Thermal Management at (661) 294-7999 M-F, 8:30 - 4:30 PST for the name of your closest distributor, for more information on the products mentioned above, or to request a catalog showing our many other quiet cooling products.

We manufacture a complete line of equipment and enclosure coolers designed to make the designers' and installers' jobs easier.

See us on the Web at www.activethermal.com.